



INSTRUMENTATION MANIFOLDS VALVES

VM Series

www.unilok.com



Features

Pressure rating up to 6000psig (413bar) @38°C (100°F)

Temperature rating from -53°C(-65°F) to 232°C (450°F) with standard PTFE packing, up to 648°C (1200°F) with Grafoil packing

Hardened stem threads and one piece of bar stock or forged body for long cycle life

Bonnet stop pin prevents accidental handle back-out

Non-rotating stem for leak-right shut-off and long cycle life

Burr-free internal surface

Manifold feature a 4:1 safety factor

2-1/8" (54mm) port centerline dimension for proper alignment

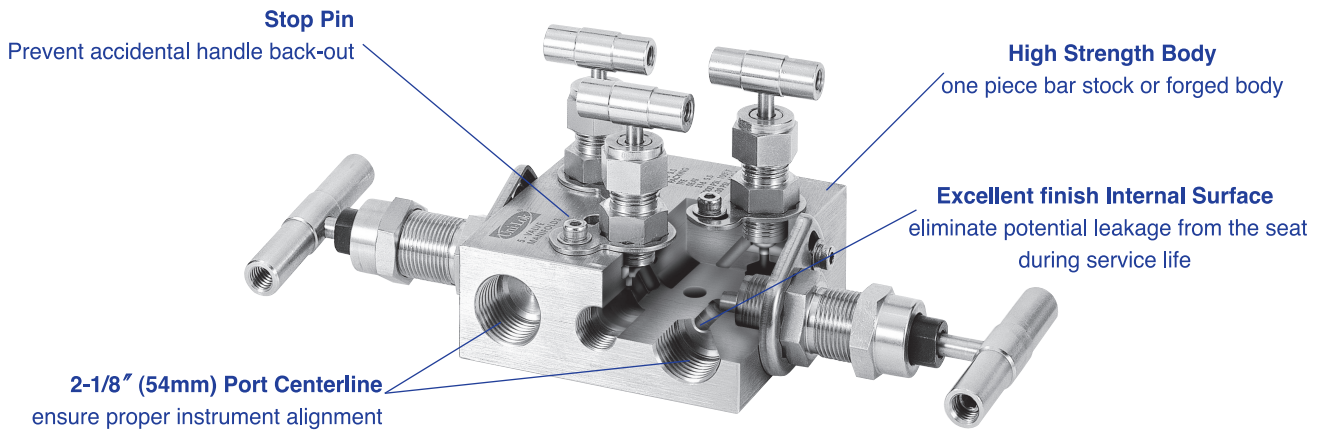

Materials of Construction

No.	Description	Materials
1	Body	316SS
2	Stem	316SS
3	Spindle Bushing	316SS
4	Packing Ring	316SS
5	Packing	PTFE
6	Gland	316SS
7	Valve Nut	304SS
8	Bar Handle	304SS
9	Stem	316SS
10	Bonnet	316SS
11	Spindle Bushing	316SS
12	Packing	PTFE
13	Jam Nut	316SS
14	Bar Handle	304SS
15	Stop Pin	304SS
16	Set Screw	304SS

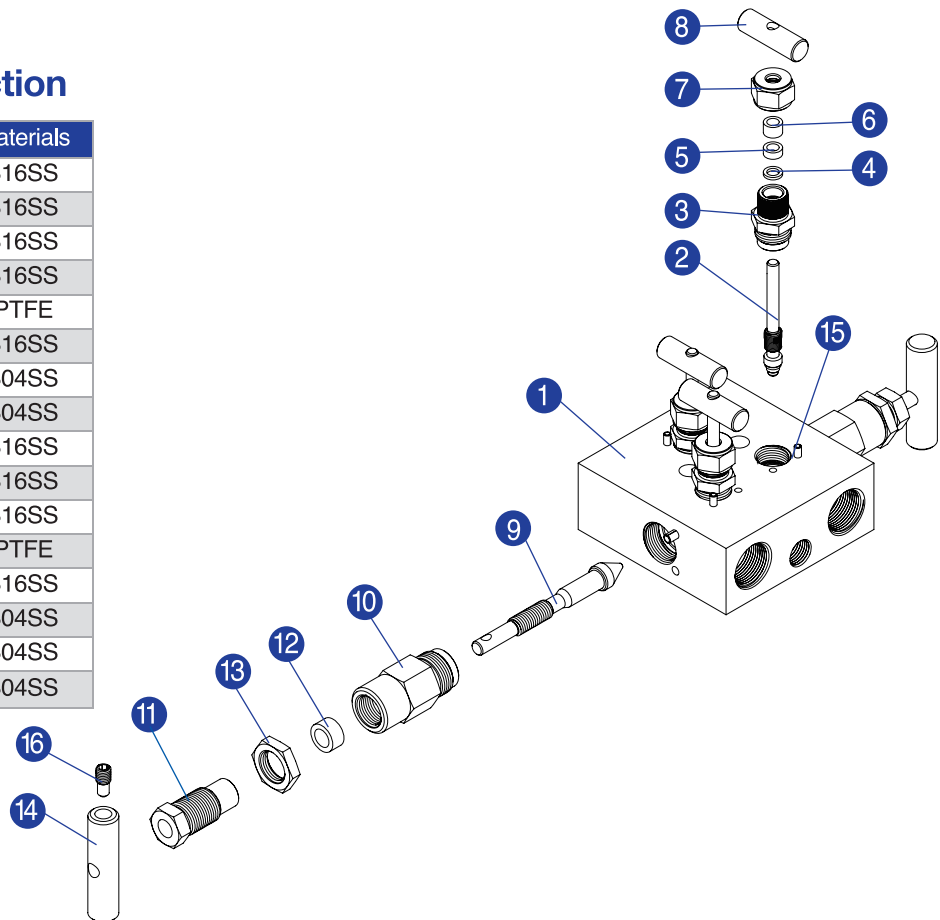

Application

2 Way Manifolds - Static pressure and liquid level applications

3 & 5 Way Manifolds - Most differential pressure transmitters with both female and flange process impulse line connections

Sour Environment Services

UNILOK valves are comply with NACE MR-0175/ISO 15156 for sour oilfield application or NACE MR-0103 for petroleum refining operations.

To order, add-N to the end of part number.

Cleaning

UNILOK valves are free from machine oils, loose particles and grease throughout the close cleaning process.

How To Order

UNILOK VM series manifolds valves are ordered by part number as shown below.

Testing

Every valve is 100% factory tested with air and nitrogen at 1000psig(69bar) for leakage at the seat and packing. Each test is performed to a maximum allowable leak rate of 0.1scc/min.

Hydrostatic shell test to be performed at 1.5 time of the working pressure is available as optional.

Important Notification

Proper installation, materials compatibility, operation and maintenance of these valves are the responsibility of the user. The total system design must be taken into consideration to ensure optimal performance and safety.

The packing adjustment may be required during the valve's service life.

Example : The following part number, **VMR2A-08N-SS** is designated for VMR series manifolds valve with both 1/2" Female NPT Threads, 316SS, PTFE packing.

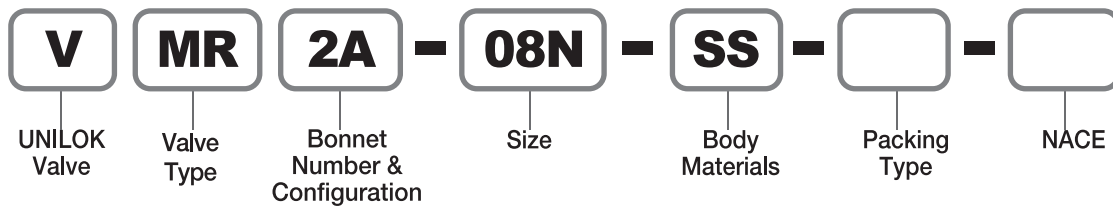

Valve Type	
MR	Remote Mounting
MD	Direct Mounting
MFL	Direct Mounting with Single Flange
MFLD	Direct Mounting with Double Flanges

Bonnet Valve Number & Configuration	
2	2 Way
3	3 Way
5	5 Way

For more details, refer to Visual Index of Manifolds Valve on page 4.

Body Materials	
SS	316SS
MO	Alloy 400

Other alloys are available upon request.

Pipe Size Designation (NPT)		
Pipe Size	1/2	1/4
Designator	08N	04N

1/4" Female NPT, bleed port is available as optional.

Packing Materials	
Nil	PTFE
GF	Grafoil

Bonnet Specification

Small Bonnet Valve

Orifice - 3.2

Large Bonnet Valve

Orifice - 6.4

Medium Bonnet Valve

Orifice - 5.0

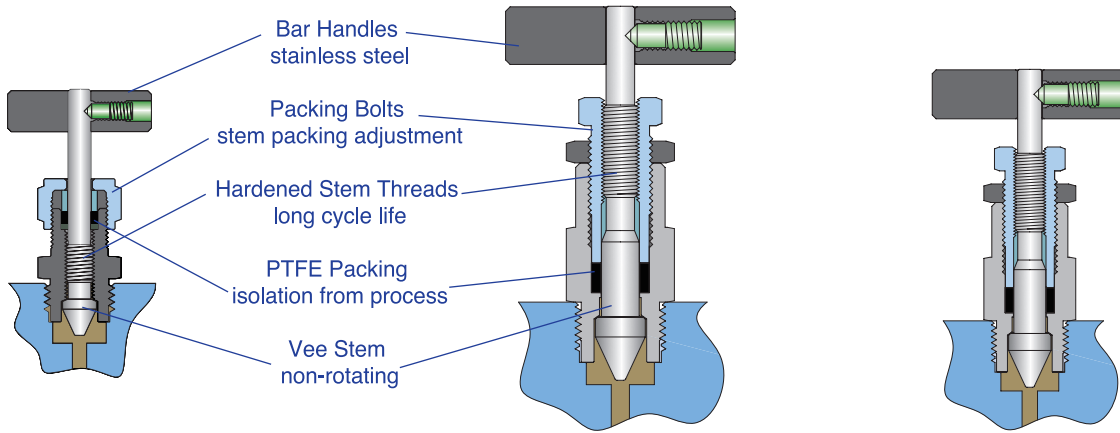

Visual Index of Manifolds Valve

	Remote Mounting	Direct Mounting
2 Way	<p>VMR2A VMR2B</p>	<p>VMD2A VMD2B VMFL2</p>
3 Way	<p>VMR3A</p>	<p>VMD3A VMD3B VMD3C VMFL3 VMFLD3</p>
5 Way	<p>VMR5A</p>	<p>VMD5A VMD5B VMFL5 VMFLD5</p>

VMR series

(2 & 3 Way, Remote Mounting Type)

VMR2A-08N-

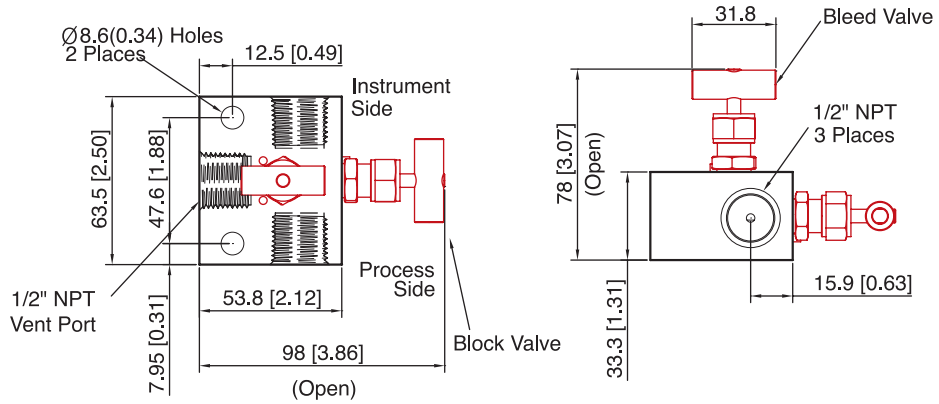
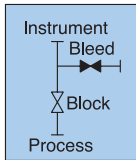
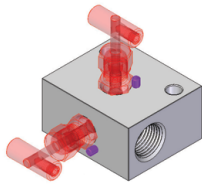

VMR2B-08N-

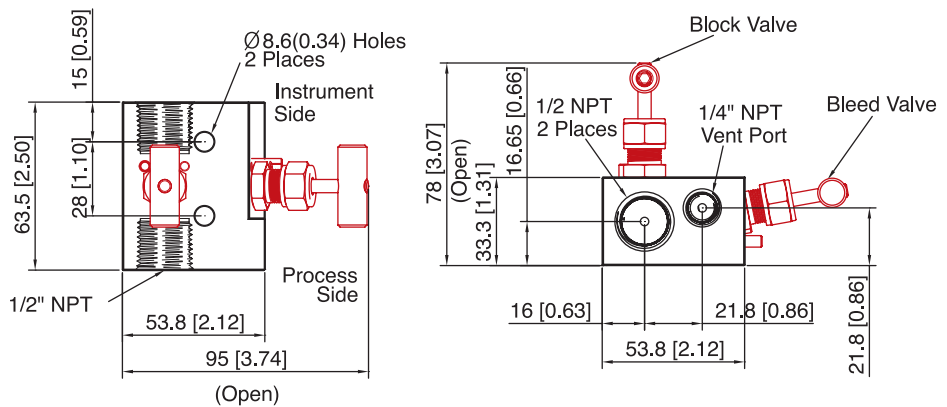
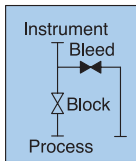
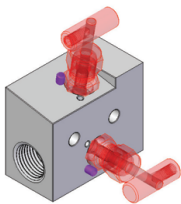

VMR3A-08N-

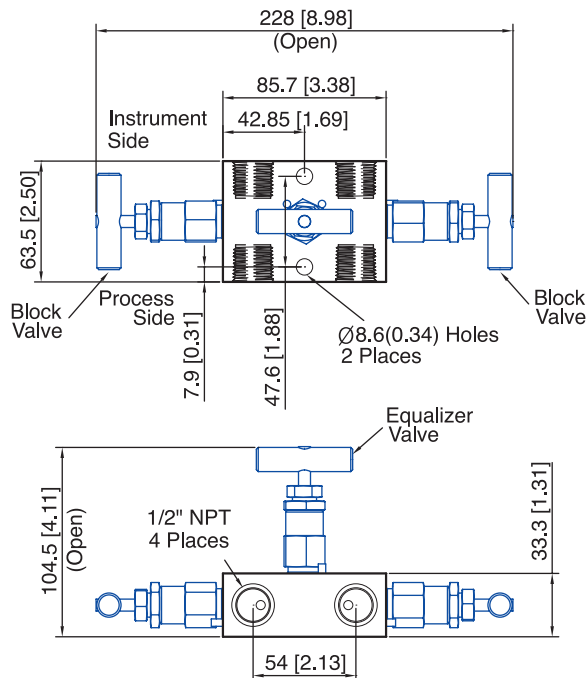
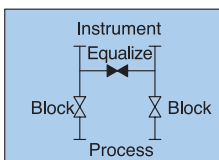
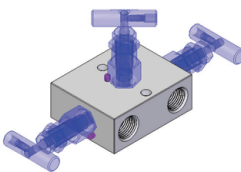

Dimensions are for reference only and are subject to change without prior notice.

VMR series

(5Way, Remote Mounting Type)

VMR5A-08N-

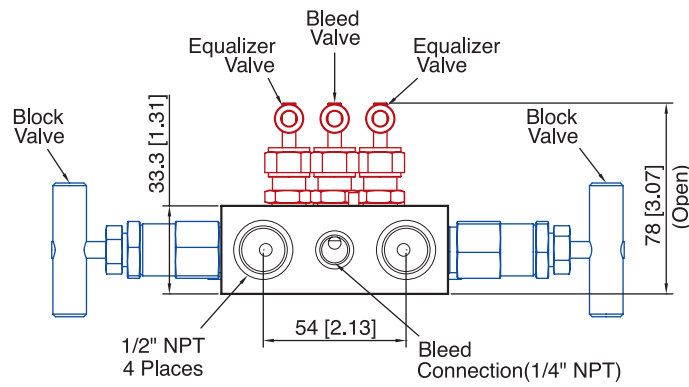
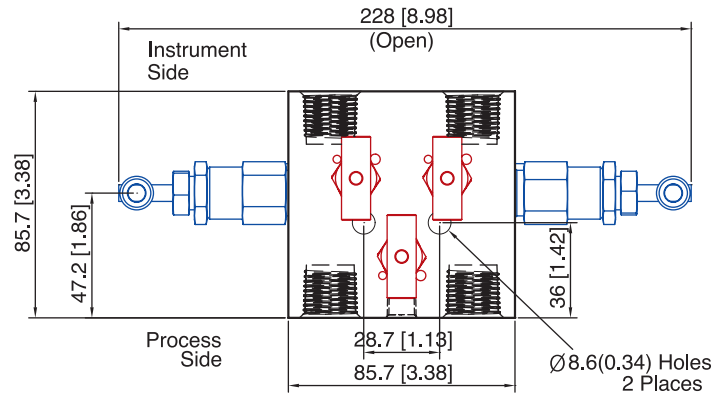
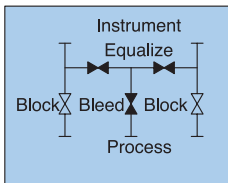
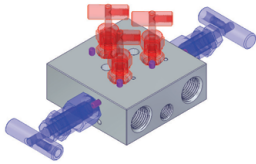

Pressure - Temperature Ratings by Packing Materials

Packing Material	Body Material	Temperature Rating		Pressure Rating at 37° C (100° F)		Pressure Rating at Maximum Temperature			
		° C	° F	psig	bar	psig	bar	° C	° F
PTFE	316SS	-54~232	-65~450	6000	413	4130	285	232	450
	Alloy 400	-54~232	-65~450	5000	345	3970	274	232	450
Grafoil	316SS	-54~648	-65~1200	6000	413	1715	118	648	1200
	Alloy 400	-54~260	-65~500	5000	345	3970	274	260	500

Alloy 400/Monel is not applicable over 260° C (500° F).

Dimensions are for reference only and are subject to change without prior notice.

VMD series

(2 & 3 Way, Direct Mounting Type with Block Flange)

VMD2A-08N- (with single block flange)

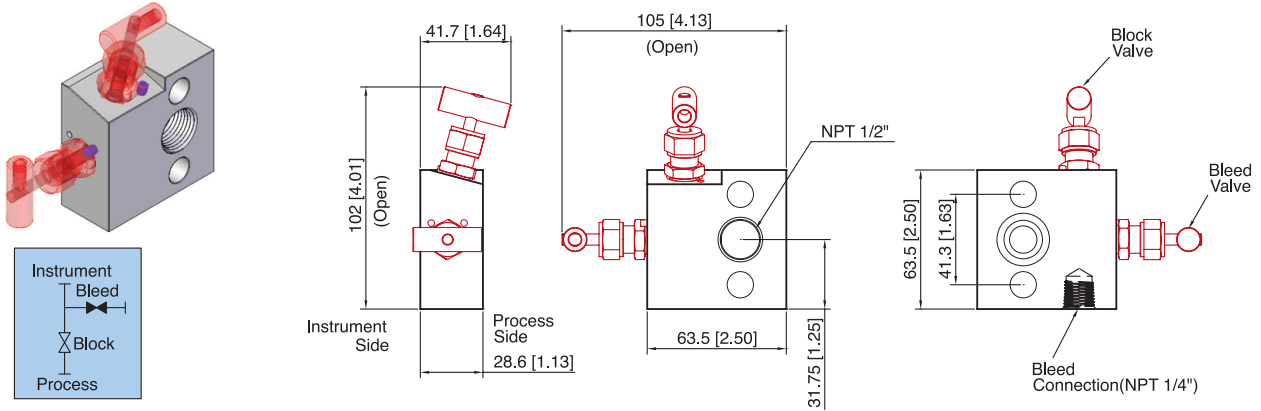

VMD2B-08N- (with single block flange)

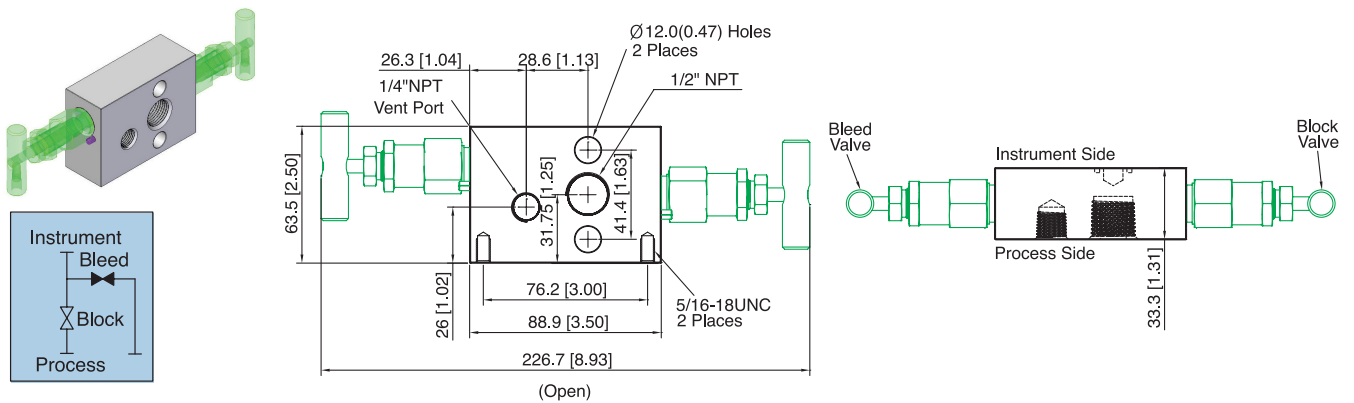

VMD3A-08N- (with single block flange)

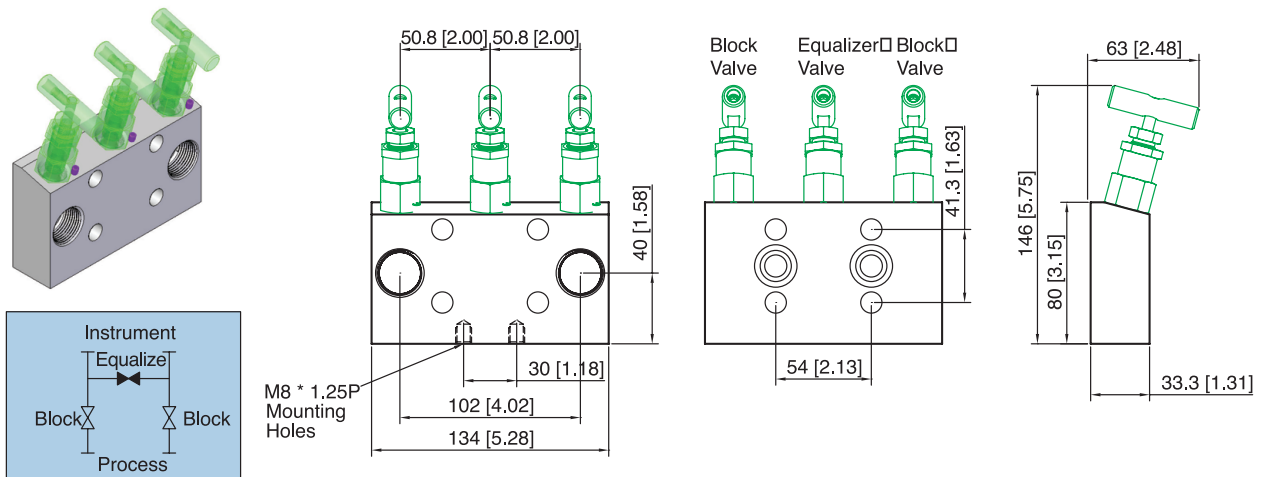

Dimensions are for reference only and are subject to change without prior notice.

VMD series

(3Way, Direct Mounting Type with Block Flange)

VMD3B-08N- (with single block flange)

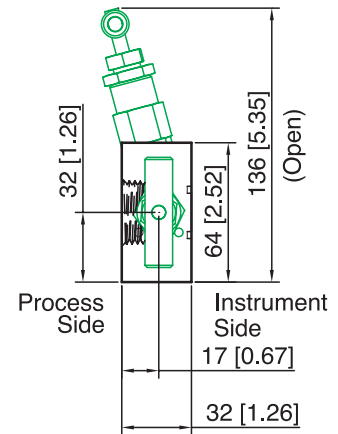
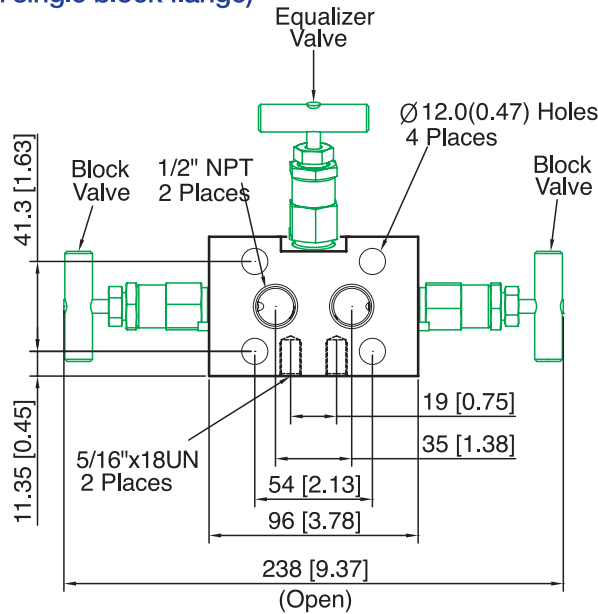
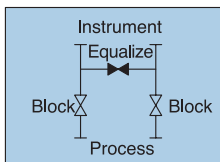
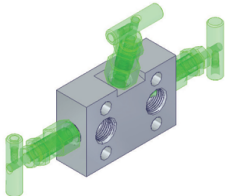

VMD3C-08N- (with double block flange)

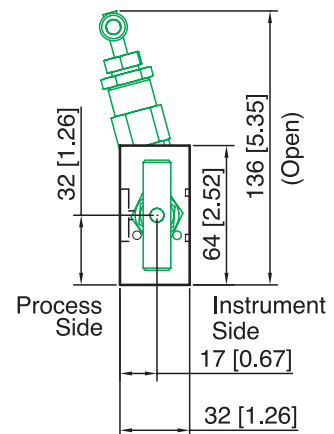
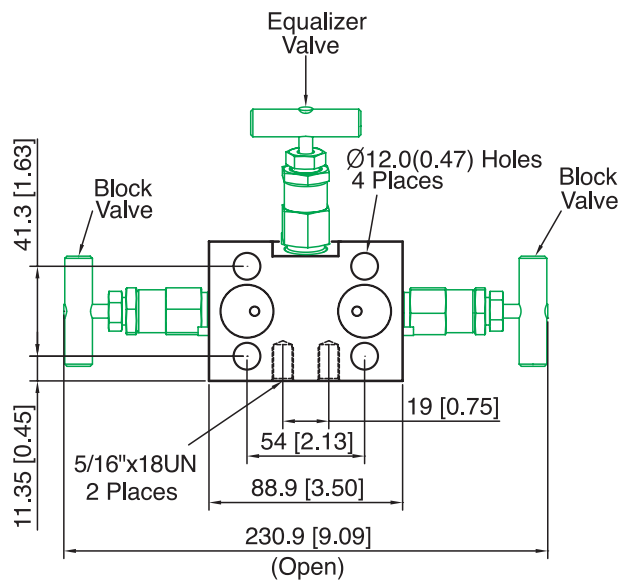
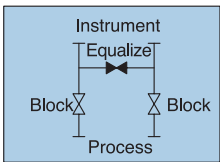
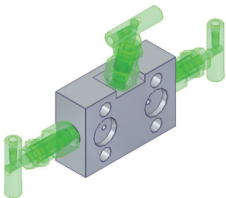

Dimensions are for reference only and are subject to change without prior notice.

VMD series

(5Way, Direct Mounting Type with Block Flange)

VMD5A-08N- (with single block flange)

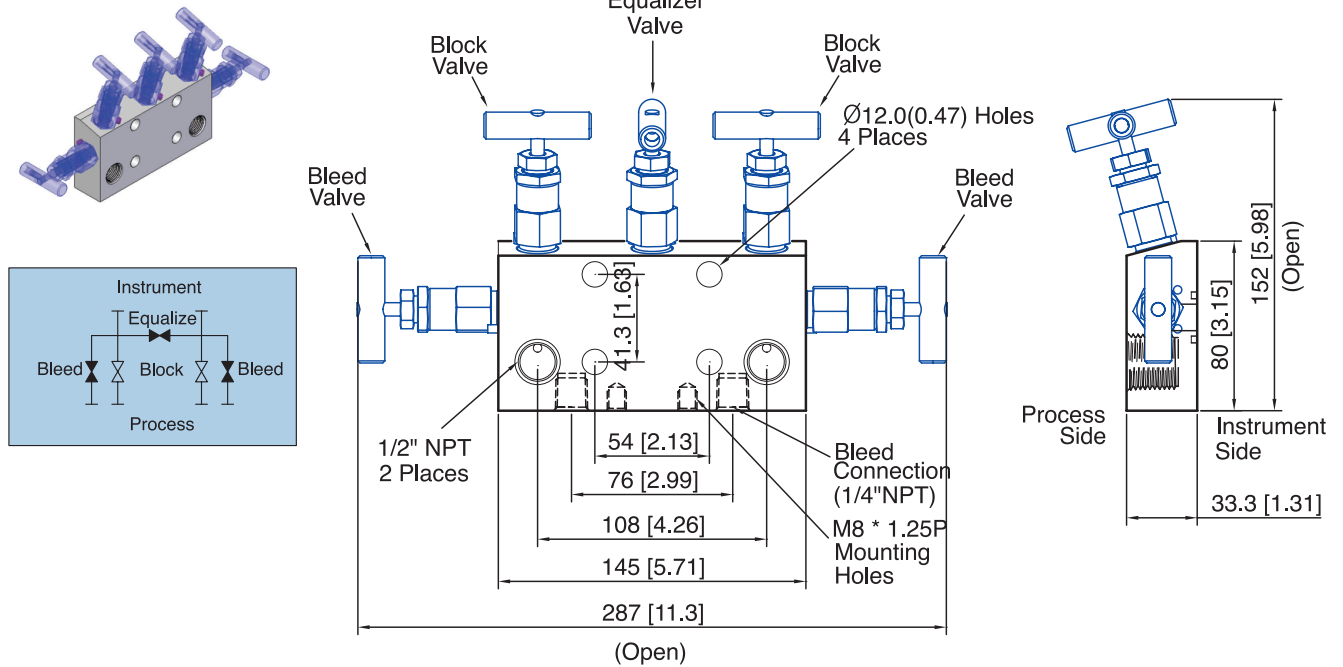

VMD5B-08N- (with single block flange)

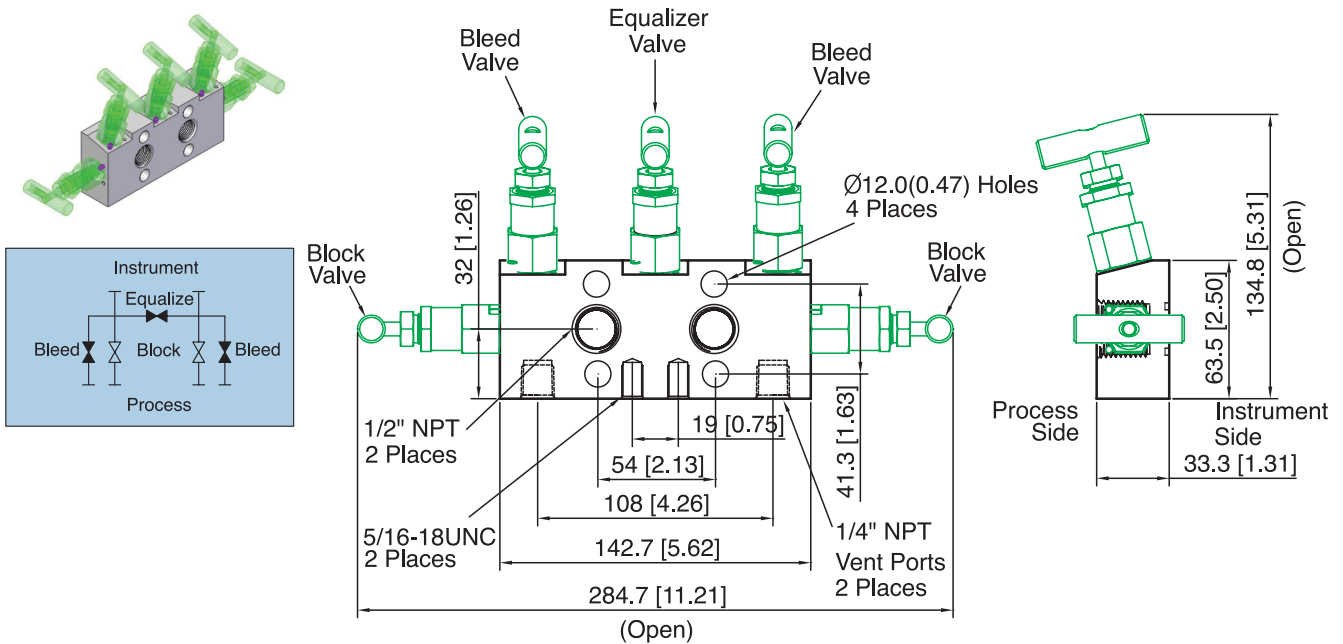

Dimensions are for reference only and are subject to change without prior notice.

VMFL series

(2 & 3 Way, Direct Mounting Type with Flange)

VMFL2-08N- (with single flange)

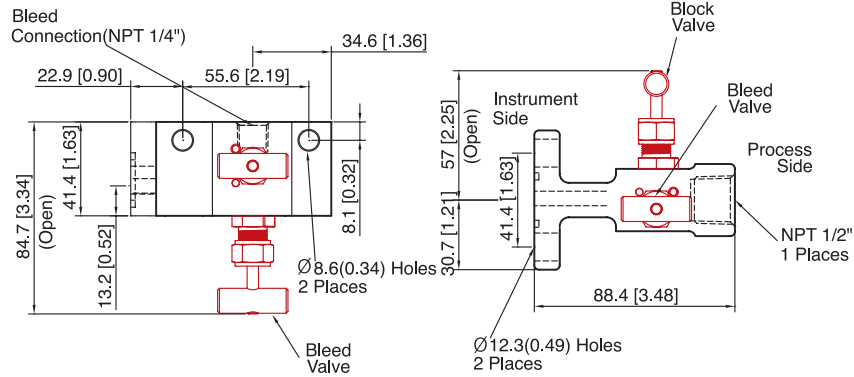
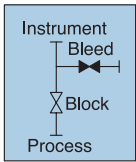
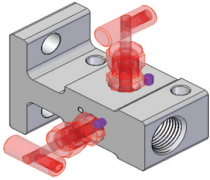

VMFL3-08N- (with single flange)

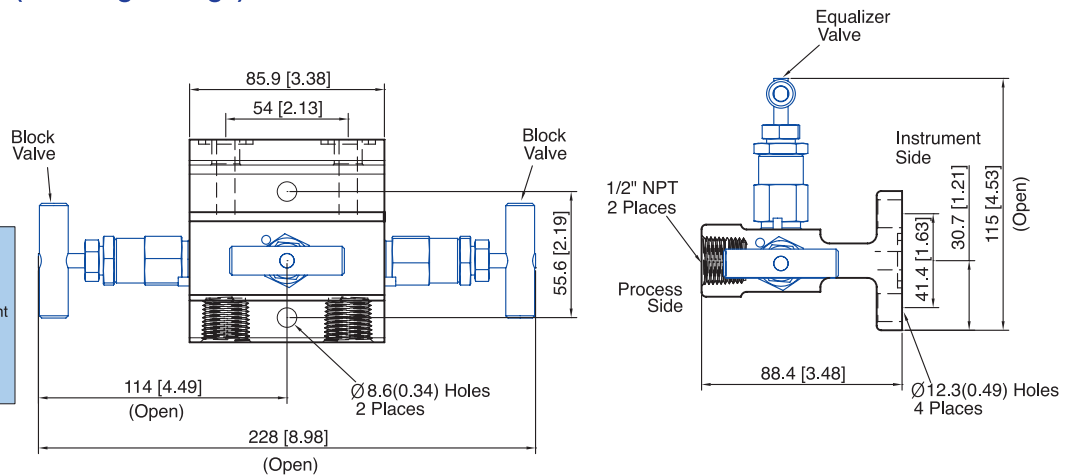
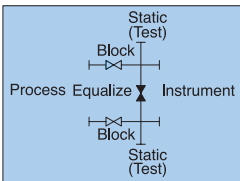
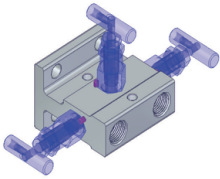

VMFLD3-08N- (with double flange)

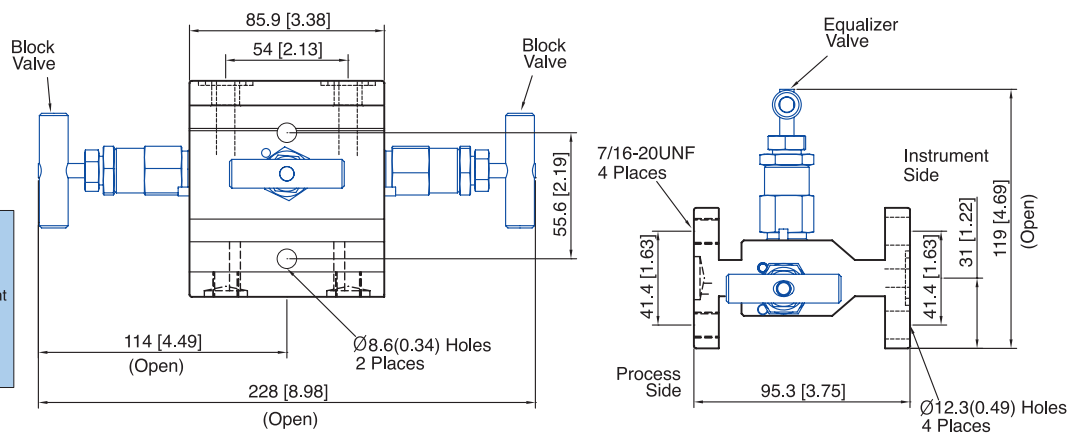
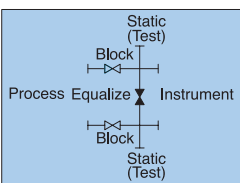
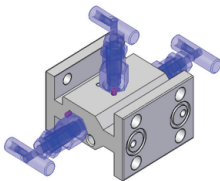

Dimensions are for reference only and are subject to change without prior notice.

VMFL series

(5Way, Direct Mounting Type with Flange)

VMFL5-08N- (with single flange)

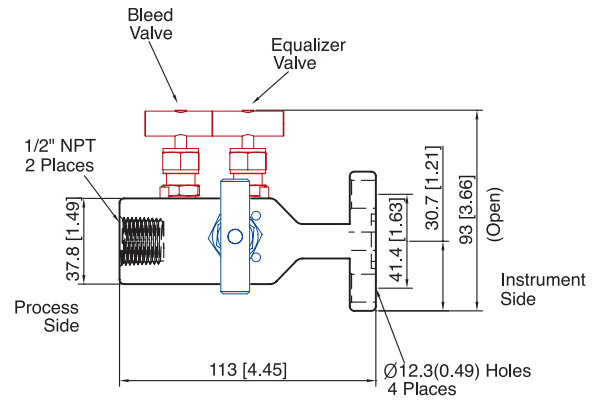
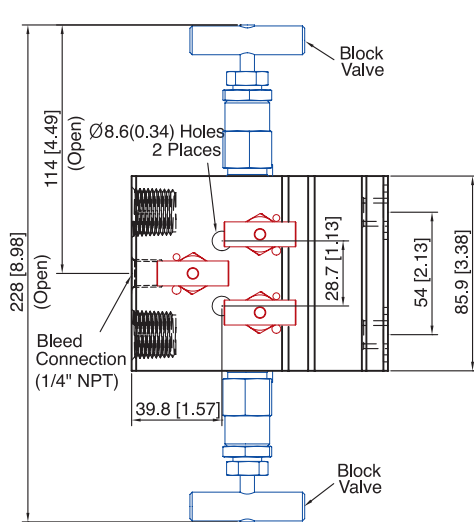
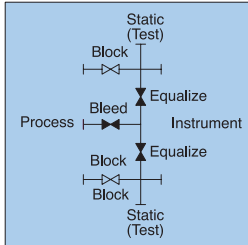
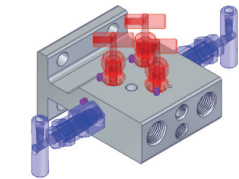

VMFLD5-08N- (with double flange)

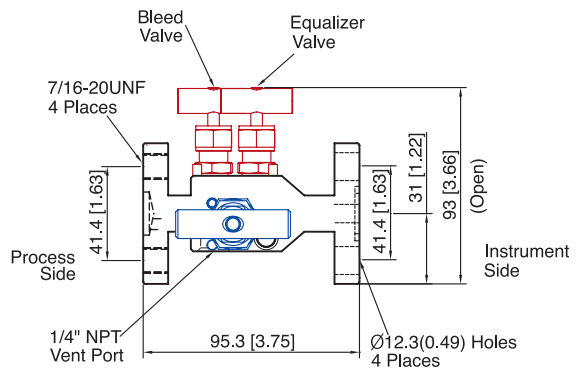
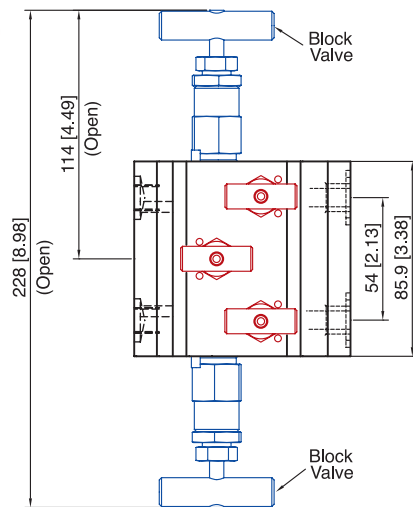
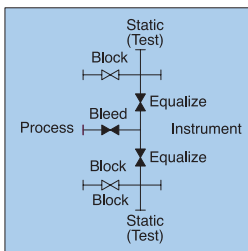
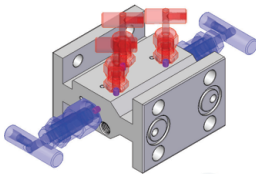

Dimensions are for reference only and are subject to change without prior notice.

Pressure - Temperature Ratings of 316SS Construction

Temperature		Working Pressure			
		PTFE		Grafoil	
°C	°F	psig	bar	psig	bar
37	100	6000	413	6000	413
93	200	5160	355	5160	355
121	250	4910	338	4910	338
148	300	4660	321	4660	321
176	350	4470	307	4470	307
204	400	4280	294	4280	294
232	450	4130	284	4130	284
260	500	-	-	3980	274
287	550	-	-	3870	266
315	600	-	-	3760	259
343	650	-	-	3700	254
371	700	-	-	3600	248
398	750	-	-	3520	242
426	800	-	-	3460	235
454	850	-	-	3380	232
482	900	-	-	3280	225
510	950	-	-	3220	221
537	1000	-	-	3030	208
565	1050	-	-	3000	206
593	1100	-	-	2685	184
621	1150	-	-	2285	157
648	1200	-	-	1715	118

Mounting Bracket Kit

Mounting bracket kit contains bracket, U-bolt and nut, bolt, nut and washer for horizontal and vertical manifold mounting. Materials are 304SS.

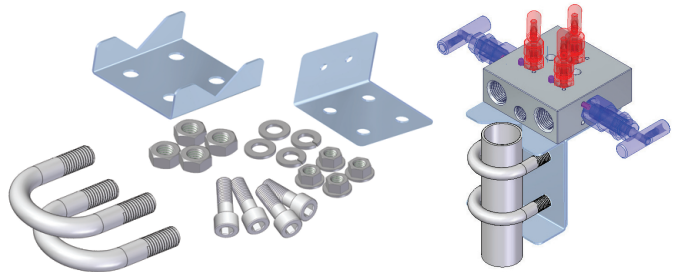

Part number for ordering is VMP-BK-SS.

Bonnet Valve Kit

Bonnet valves are available for replacement.

Part Number	Bonnet Valve Size	Packing Material
VMP-BV-S	Small	PTFE
VMP-BV-M	Medium	
VMP-BV-L	Large	

Dimensions are for reference only and are subject to change without prior notice.



CONNECTS THE WORLD SINCE 1984 www.unilok.com

본사 및 제1공장
 인천광역시 남동구 남동동로 64번길 37
 남동공단 152블럭 12롯데
 전화 : 032-822-6600
 팩스 : 032-822-6604

제2공장
 인천광역시 남동구 남동서로 83번길 87
 남동공단 114블럭 8롯데
 전화 : 032-433-6601
 팩스 : 032-441-7600

Headquarters & 1st Factory
 152 Block-12 Lot, Namdong Indus-Park, 37, Namdongdong-ro
 64beon-gil, Namdong-Gu, Incheon, Korea
 Tel : +82-32-821-6673
 Fax : +82-32-822-6604

2nd Factory
 114 Block-8 Lot, Namdong Indus-Park, 87, Namdongseo-ro
 83beon-gil, Namdong-Gu, Incheon, Korea
 Tel : +82-32-433-6601
 Fax : +82-32-441-7600